

SPECIFICATION FOR APPROVAL

REF : 20111123-B

PAGE: 1

PROD. NAME	BEAD COIL	ABC'S DWG NO.	BD□□□□□□□□L□-□□□
		ABC'S ITEM NO.	

I . CONFIGURATION & DIMENSIONS :

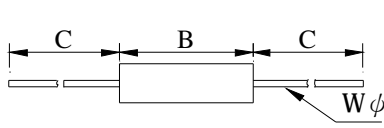

Fig : A

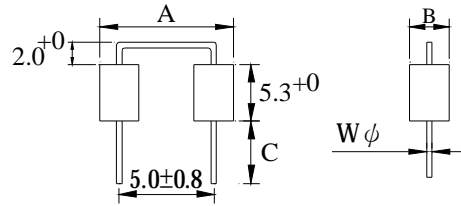
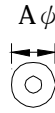

Fig : B

II . MATERIALS :

- a . Core : Ferrite RH core
- b . Lead wire : Tinned copper wire
- c . Remark : Products comply with RoHS' requirements

III . GENERAL SPECIFICATION :

- a . Operating temp. : -25°C ---- +105°C
- b . Storage temp. : -40°C ---- +125°C

1. BD0305-450Y/ 100MHz
2. BD0306-600Y/ 100MHz
3. BD0309-800Y/ 100MHz
4. BD0907-111Y/ 100MHz

V . IMPEDANCE VS. FREQUENCY RESPONSE CURVE :

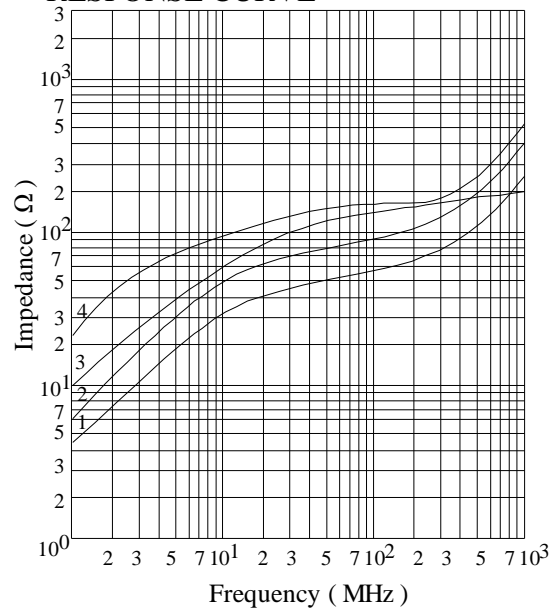

IV . ELECTRICAL CHARACTERISTICS & DIMENSIONS :

ABC'S Part No.	Impedance min. (Ω) at 100MHz	Rate current max. (A)	Dimension (m/m).				Fig.
			A m/m	B m/m	C m/m	W φ m/m	
BD0305450YL□-□□□	45	3.0	3.5±0.2	4.7±0.3	29.0±3.0	0.65φ	A
BD0306600YL□-□□□	60	3.0	3.5±0.2	6.0±0.3	28.5±3.0	0.65φ	A
BD0309800YL□-□□□	80	3.0	3.5±0.2	9.0±0.3	27.0±3.0	0.65φ	A
BD0907111YL□-□□□	110	7.0	9.0 max.	3.8 max.	4.5±1.0	0.60φ	B

- 1) □ : Packaging Information... [A]: Bulk
- 2) ."- □□□":Reference code
- 3). Test equipment : RF impedance analyzer HP4291A.
- 4). Test fixture : Spring clip fixture HP16092A.

AR-001A



SPECIFICATION FOR APPROVAL

REF : 20111123-B

PAGE: 2

PROD. NAME	BEAD COIL	ABC'S DWG NO.	BD□□□□□□□□L□-□□□
		ABC'S ITEM NO.	

VI . PACKAGING INFORMATION FOR BD HORIZONTAL TAPING IN REEL

(1) Configuration

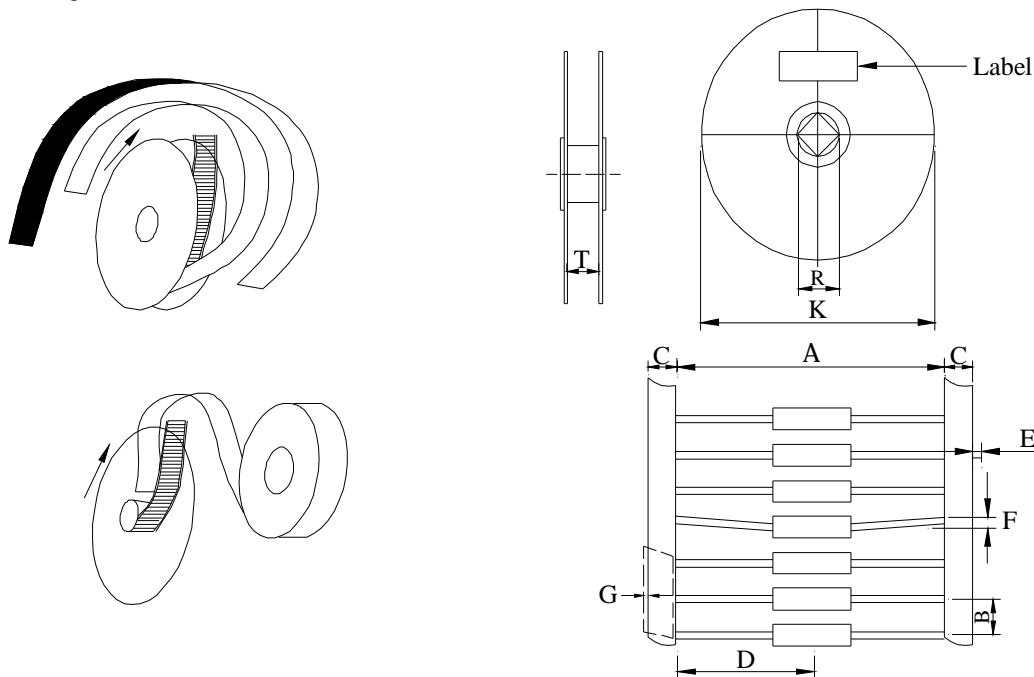

(2) Dimensions

Unit:m/m

Item	Specification	Item	Specification
A	52.00±1.50	F	1.00 (max)
B	5.00±0.50	G	1.00 (max)
C	6.00±1.00	K	355.00±0.50
D	26.00±1.50	R	15.00±0.50
E	0.00±0.50	T	71.00±3.00

(3) Q'TY & G.W. Per package

Series	Inner : Reel			Outer : Carton		
	Q'TY (pcs)	G.W. (gw)	Size (m/m)	Q'TY (pcs)	G.W. (Kg)	Size (cm)
BD0305	5,000	2,300	364 x 365 x 89	20,000	10	37.5 x 37.0 x 37.5
BD0306	5,000	2,700	364 x 365 x 89	20,000	10	37.5 x 37.0 x 37.5
BD0309	5,000	3,700	364 x 365 x 89	20,000	16.2	37.5 x 37.0 x 37.5

AR-001A

SPECIFICATION FOR APPROVAL

REF : 20111123-B

PAGE: 3

PROD. NAME	BEAD COIL	ABC'S DWG NO.	BD□□□□□□□□L□-□□□
		ABC'S ITEM NO.	

VII . PACKAGING INFORMATION FOR BD HORIZONTAL TAPING IN BOX

(1) Configuration

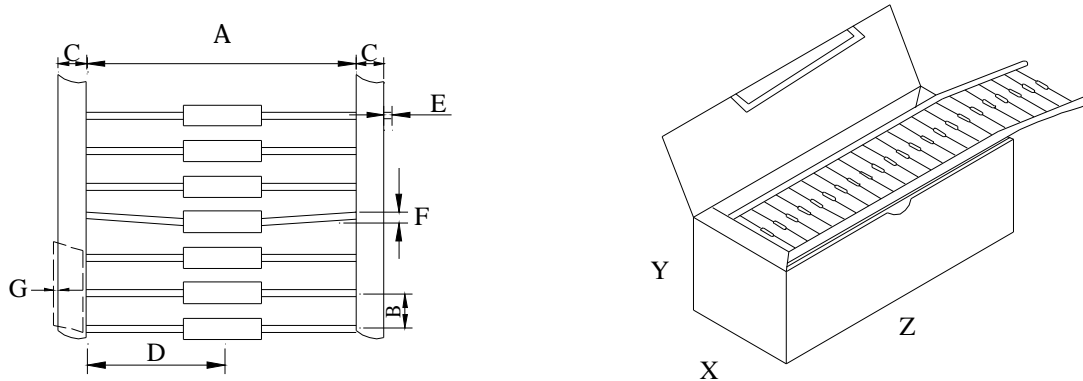

(2) Dimensions

Unit:m/m

Style	Item	Specification	Item	Specification
T 26	A	26.00±1.50	B	5.00±0.50
	D	13.00±0.50	C	6.00±1.00
	X	50.00±1.50	E	0.00±0.50
T 52	A	52.00±1.50	F	1.00 (max)
	D	26.00±1.50	G	1.00 (max)
	X	76.00±1.50		

(3) Q'TY & G.W. Per package

Serise	Inner : Box			Outer : Carton		
	Q'TY (pcs)	G.W. (gw)	Size (m/m)	Q'TY (pcs)	G.W. (Kg)	Size (cm)
BD0305	1,000	350	295 x 75 x 58	35,000	15.0	37.5 x 37.0 x 37.5
				12,000	8.5	
BD0306	1,000	450	295 x 75 x 58	24,000	15.5	37.6 x 26.6 x 34.5
				18,000	12.0	37.6 x 26.6 x 34.5
BD0309	1,000	650	295 x 75 x 58	16,000	10.5	37.6 x 26.6 x 34.5
				24,000	16.5	37.6 x 26.6 x 34.5

AR-001A

SPECIFICATION FOR APPROVAL

PROD. NAME	BEAD COIL	ABC'S DWG NO.	BD□□□□□□□□L□-□□□
		ABC'S ITEM NO.	

VIII . PACKAGING INFORMATION FOR BD VERTICAL TAPING IN BOX

(1) Configuration

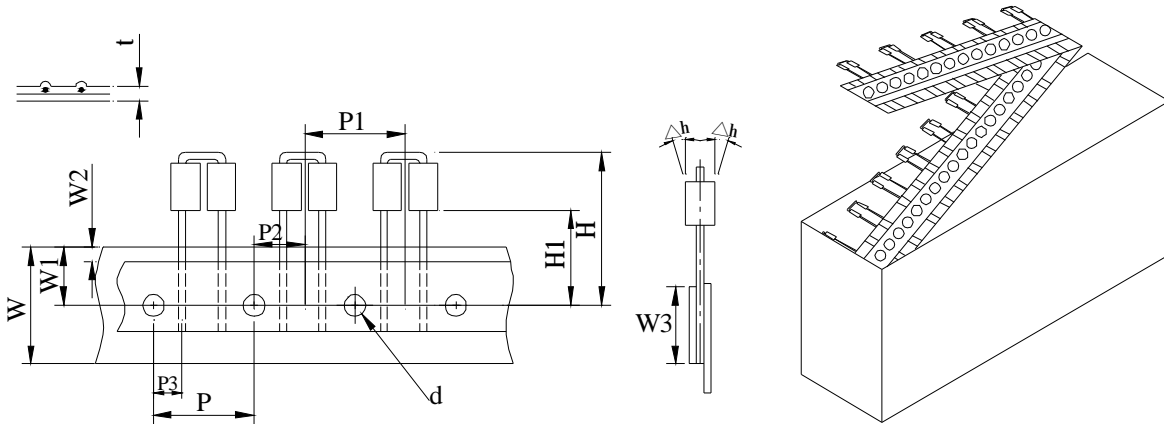

(2) Dimension

Unit:m/m

Item	Specification	Item	Specification
P	12.7 ±0.30	W3	11.0 max.
P1	12.7 ±1.00	H	27.0 max.
P2	6.35±1.00	H1	18.5±1.00
P3	3.85±0.70	△h	0.0±2.00
W	18.0±0.50	t	0.7±0.20
W1	9.0±0.50	d	4.0±0.20
W2	2.0 max.		

(3) Q'TY & G.W. Per package

Series	Inner : Box			Outer : Carton		
	Q'TY (pcs)	G.W. (gw)	Size (m/m)	Q'TY (pcs)	G.W. (Kg)	Size (cm)
BD0907	2,000	1,100	332 x 273 x 40	10,000	9.00	37.5 x 37.0 x 37.5

SPECIFICATION FOR APPROVAL

REF : 20111123-B

PAGE: 5

PROD. NAME	BEAD COIL	ABC'S DWG NO.	BD□□□□□□□□L□-□□□
		ABC'S ITEM NO.	

VIII . PACKAGING INFORMATION FOR BD VERTICAL TAPING IN BOX

(Packaging Code : F)

(1) Configuration

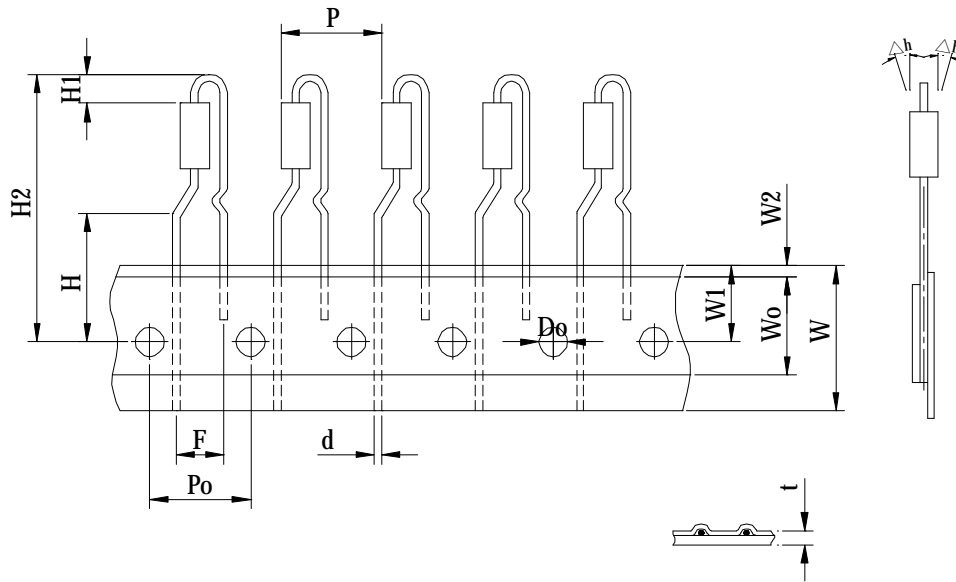

(2) Dimension

Unit:m/m

Item	Specification	Item	Specification
P	12.70 ±1.00	H1	3.00 max.
Po	12.70 ±0.30	W	18.00 ⁺⁰ / _{-0.5}
d	φ0.65 or ψ0.5	W0	12.50 min.
F	5.00±0.80	W1	9.00±0.80
Do	φ4.00±0.30	W2	1.00 max.
H	16.00±1.00	t	0.70±0.30
△h	0.00±1.00	H2	32.60 max.

AR-001A

SPECIFICATION FOR APPROVAL

PROD. NAME	BEAD COIL	ABC'S DWG NO.	BD□□□□□□□□L□-□□□
		ABC'S ITEM NO.	

IX . DWGING NUMBER EXPRESSION :

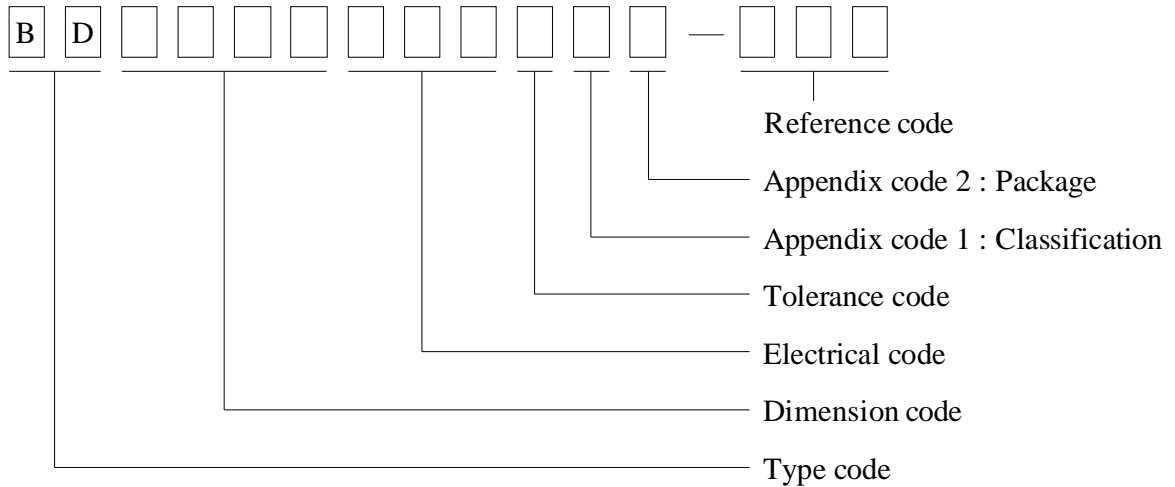

Appendix code 1 : Product Classification

- L : Lead Free Standard products comply with RoHS' requirements
- 1 ~ 9 : Lead Free Special products comply with RoHS' requirements

Appendix code 2 : Package Information

Code	Inner package	Inner package Q'TY	Remark
A	Bag	200 pcs	BD0304
		200 pcs	BD0305
		200 pcs	BD0306
		200 pcs	BD0309
		200 pcs	BD0907
B	T / B (T52 Box package)	1000 pcs	BD0305
		1000 pcs	BD0306
		1000 pcs	BD0309
	T / B (Box ammo package)	2000 pcs	BD0907
C	T / R (T52 Reel package)	5000 pcs	BD0304
		5000 pcs	BD0305
		5000 pcs	BD0306
		5000 pcs	BD0309
		T.B.D.	BD0907

SPECIFICATION FOR APPROVAL

PROD. NAME	BEAD COIL	ABC'S DWG NO.	BD□□□□□□□□L□-□□□
		ABC'S ITEM NO.	

IX . DWGING NUMBER EXPRESSION :

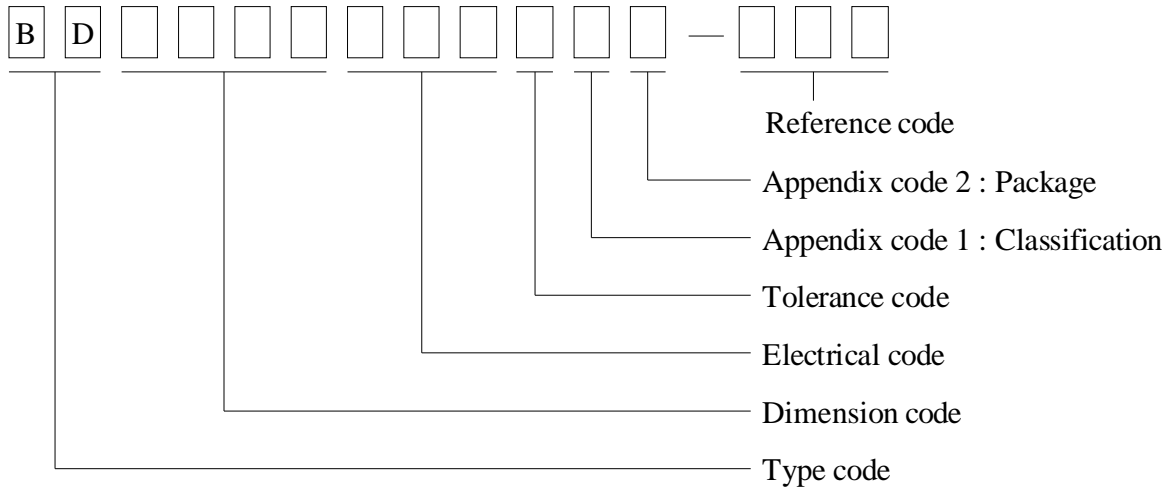

Appendix code 1 : Product Classification

- L : Lead Free Standard products comply with RoHS' requirements
- 1 ~ 9 : Lead Free Special products comply with RoHS' requirements

Appendix code 2 : Package Information

Code	Inner package	Inner package Q'TY	Remark
D	T / B (T26 Box package)	1000 pcs	BD0305
		1000 pcs	BD0306
		1000 pcs	BD0309
E	T / R (T26 Reel package)	5000 pcs	BD0305
		4000 pcs	BD0306
		5000 pcs	BD0309
F	T / B (Radial Fm)	2000 pcs	BD0305
		2000 pcs	BD0306